

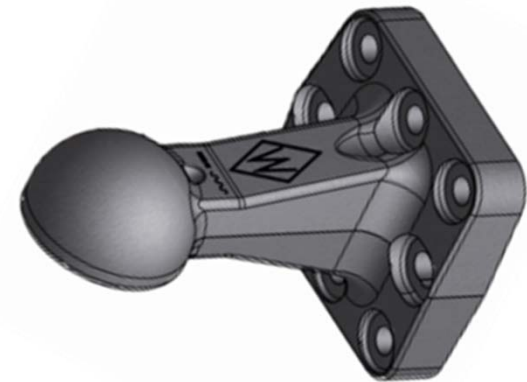

Pourquoi une boule ?

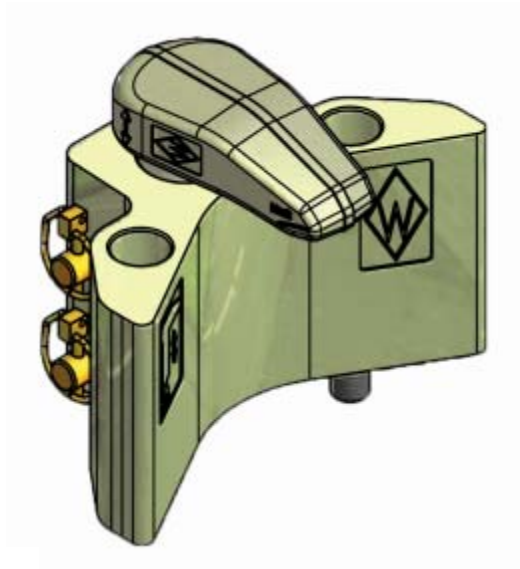



Caractéristiques du produit Walterscheid



- Remplaçable jusqu'à 2 fois dans la vie d'une barre
- Le plus grand angle sur le marché

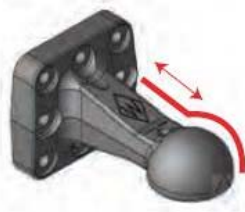

- Calotte forgée pour un accouplement durable et précis
- Notre système boule + calotte offre le plus grand débattement angulaire sur le marché.



- Rotation 360 ° libre pour vue imprenable lors de l'accouplement
- Dispositif de capture avec centrage forgé
- Ajustement sans outil



- Pleine Largeur du support de la barre de tire
- Conception modulaire pour des composantes d'accouplement interchangeables





Boule Walterscheid K80

- Boule en forme de ballon pour des grands angles de mouvement
- Remplaçable jusqu'à 2x

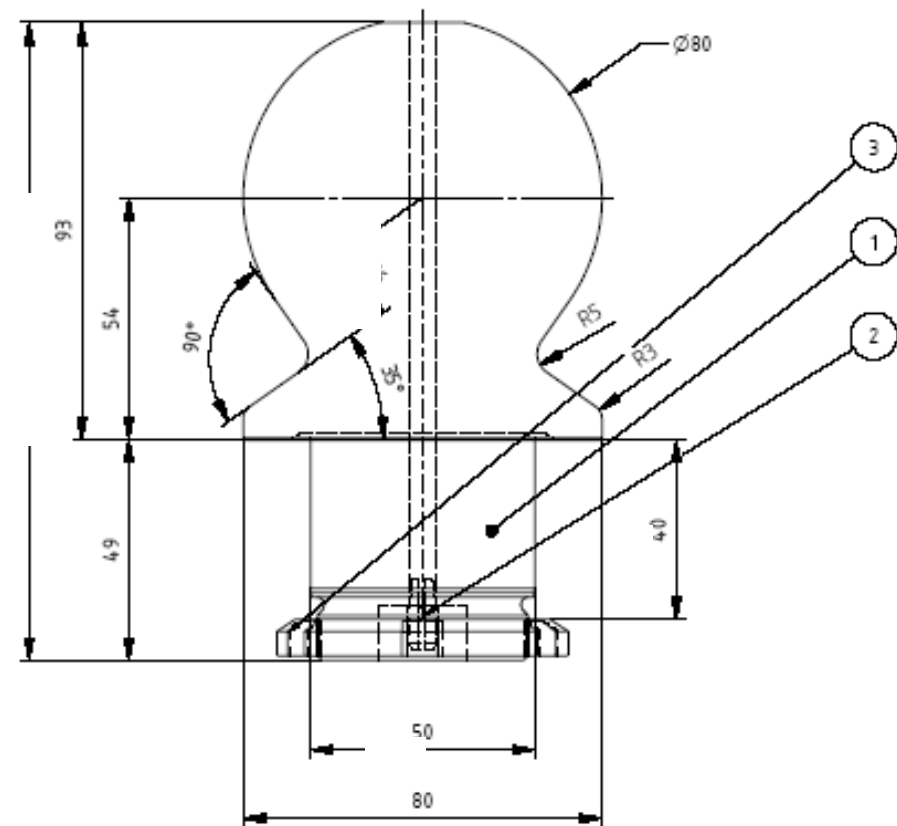



Comparaison des angles de travail

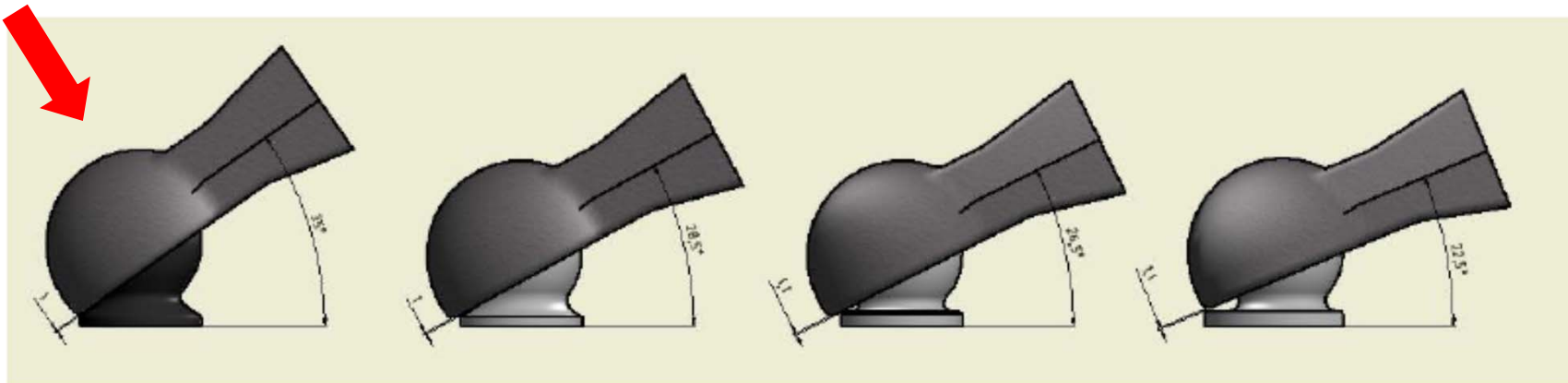

En utilisant les boules Walterscheid, les angles les plus élevés sont atteints de bas en haut

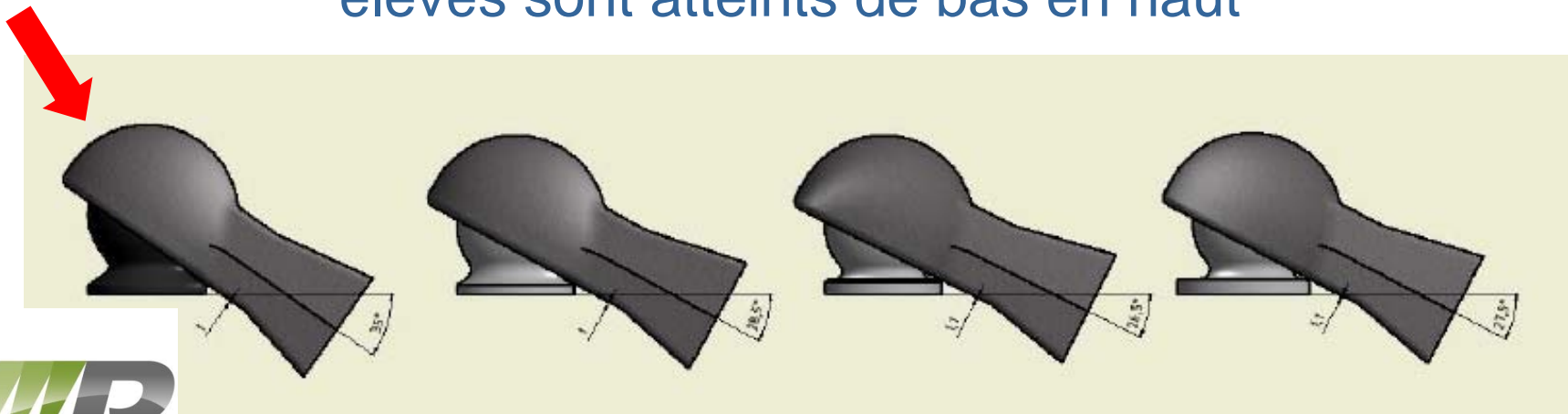



Une calotte mobile !!

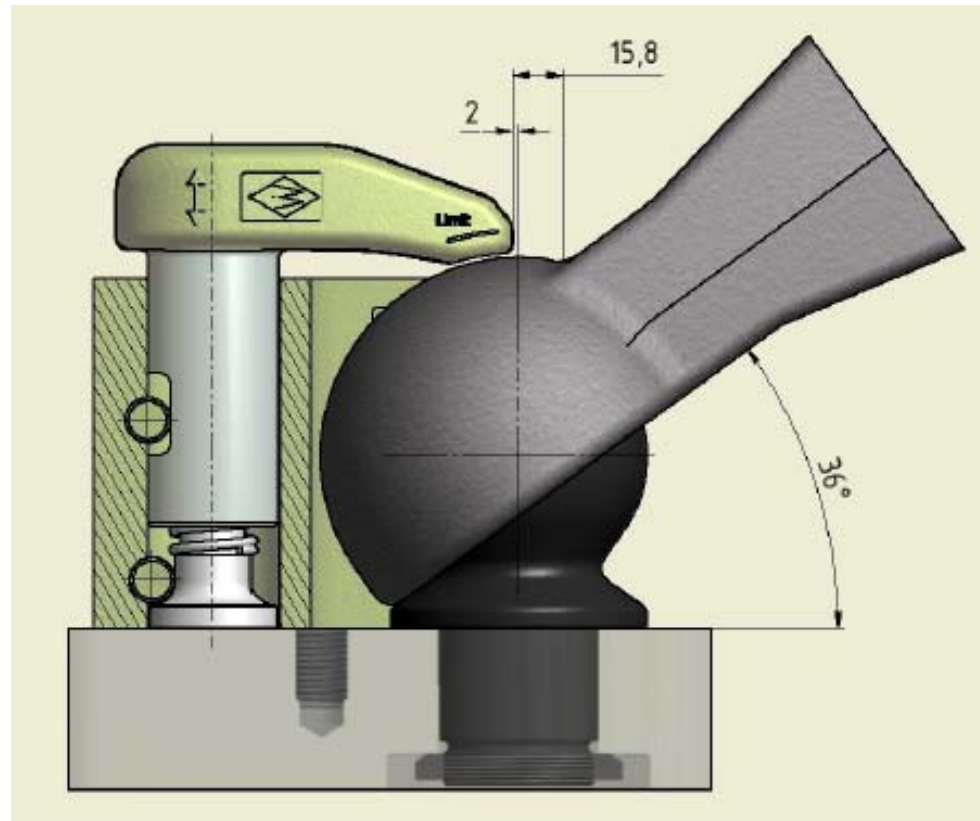

Angle maximum possible jusqu'à 36 °





Calotte

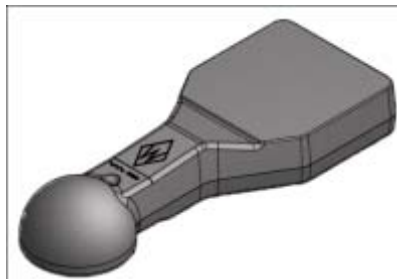
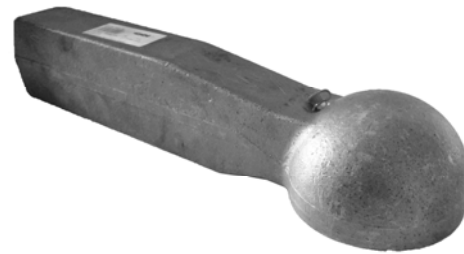



Retenue Walterscheid accouplements K80

- > Retenue forgé pour recevoir des charges négatives élevées (10t)
- > Réglable sans outil, orientable sur 360 °

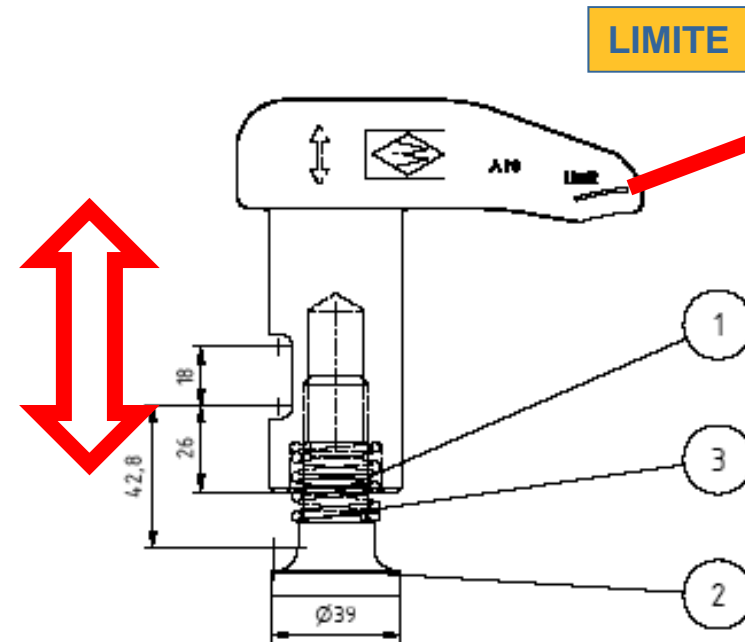

LIMITE





Ajustement sans outils

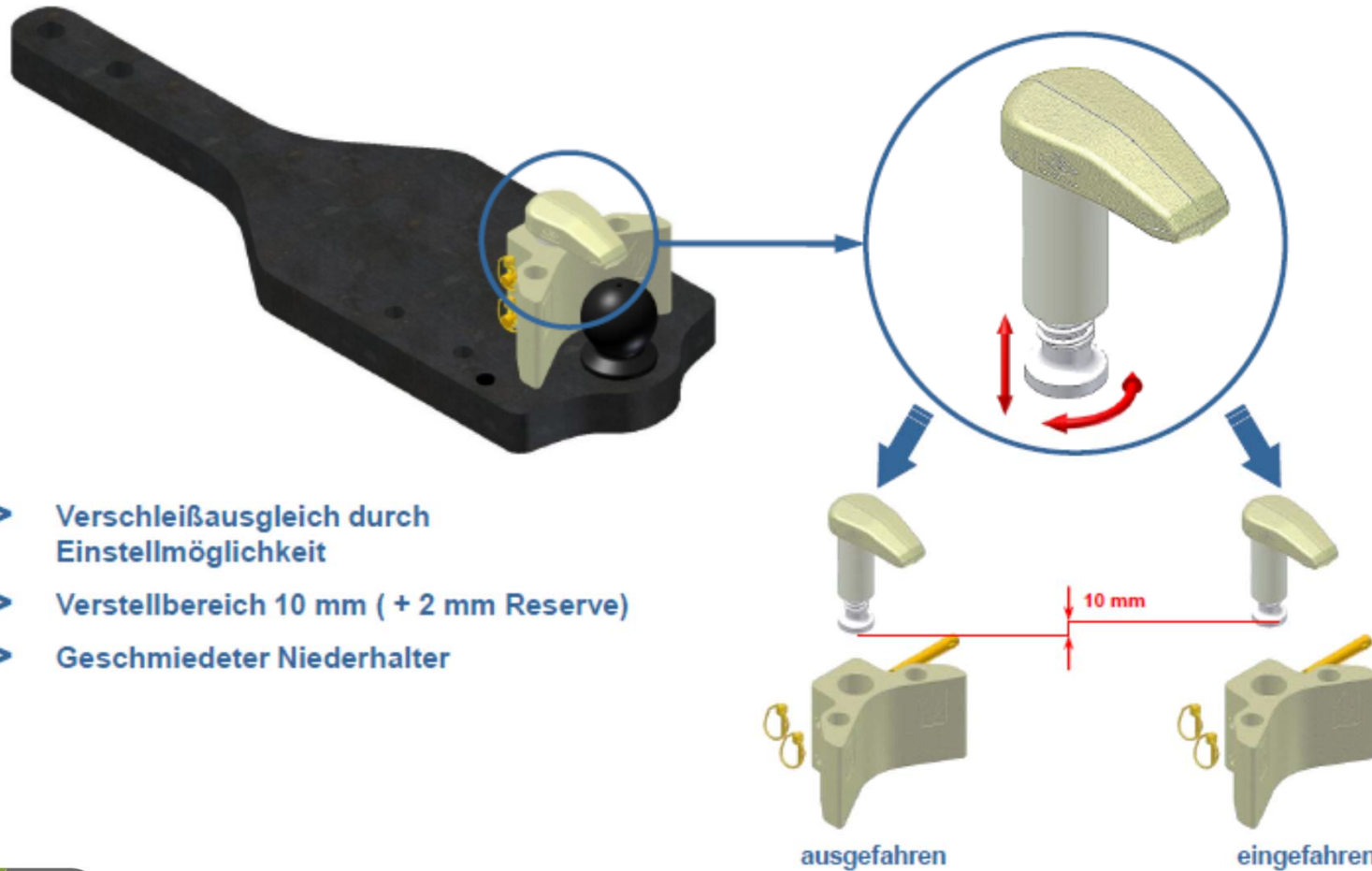
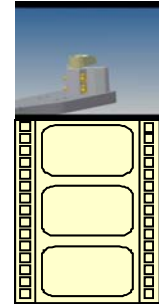

- Verschleißausgleich durch Einstellmöglichkeit
- Verstellbereich 10 mm (+ 2 mm Reserve)
- Geschmiedeter Niederhalter

